

BHS
SONTHOFEN

PB & PM

Impact Crushers & Impact Mills

For top crushing performance

TRANSFORMING
MATERIALS
INTO VALUE

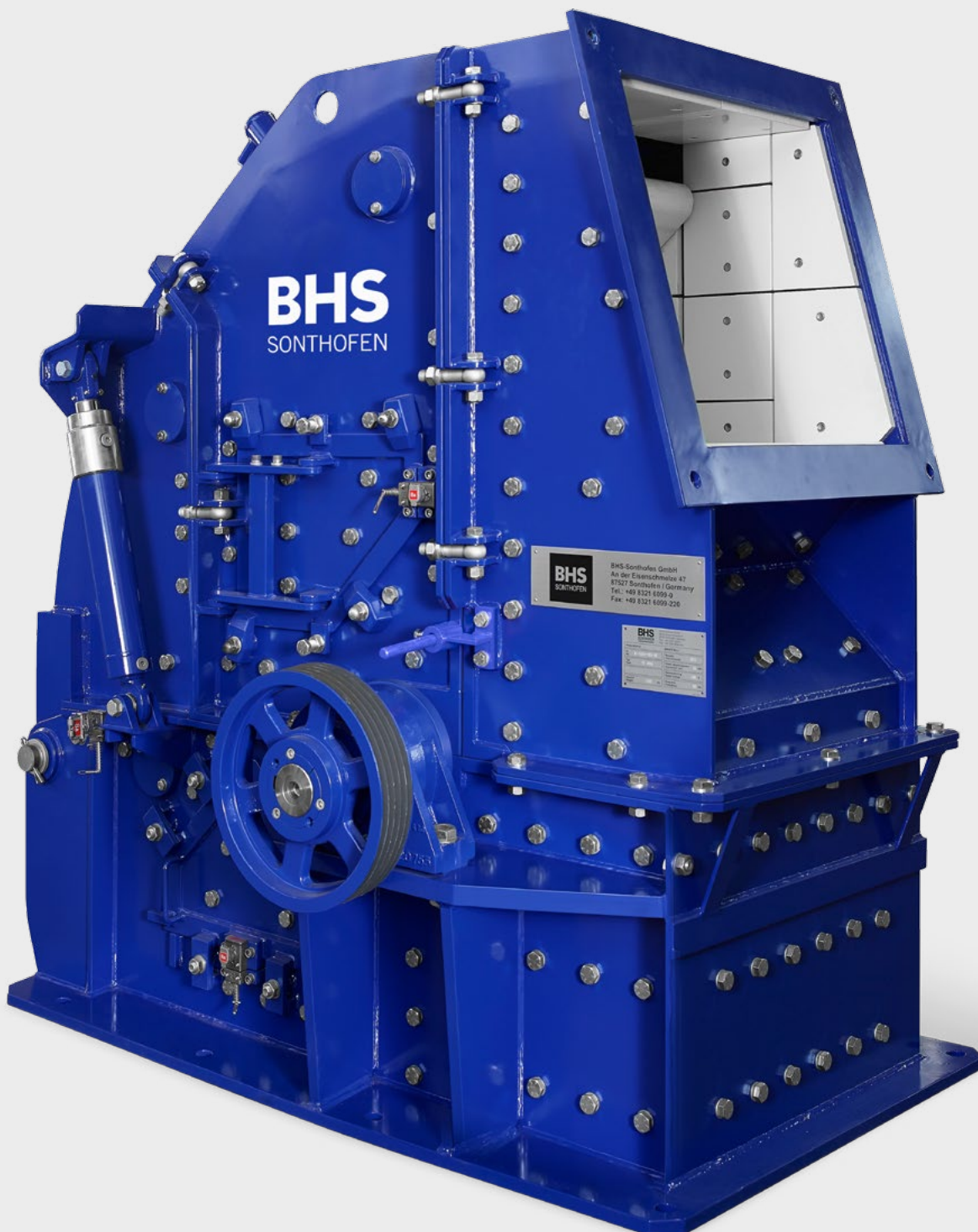

Headquarters of BHS-Sonthofen



TRANSFORMING MATERIALS INTO VALUE

BHS
SONTHOFEN



The company

BHS-Sonthofen, headquartered in Sonthofen, Germany, is an owner-operated group of companies in the field of machine and plant engineering. We offer technical solutions in the field of mechanical process engineering, with a focus on mixing, crushing, recycling and filtration. With over 300 employees and a number of subsidiaries, BHS-Sonthofen has a global presence.

Experience

We have been manufacturing crushers and mills for over 100 years. Today, these many years of experience form the basis for our sophisticated machines with a focus on impact crushing.

Crushing trials in the BHS technical center

BHS offers customers the opportunity of conducting crushing trials with their own materials at the technical center in Sonthofen. These provide an important basis for deciding how to optimize planned upstream and downstream processes and information about the final product results that are to be expected.

Worldwide service

BHS offers quick and reliable service worldwide with its technical customer support and a large stock of spare parts for all standard machine types and also for older machines.

www.bhs-sonthofen.com

BHS Impact Crusher & Impact Mill

BHS Impact Crushers and Impact Mills are a universal and, at the same time, economical solution. The BHS Impact Crusher achieves very high crushing ratios in both the first and second stage. This already results in a broad range of saleable cubical final products. To manufacture fine grains, the Impact Crusher can with the addition of the lower section grinding track be converted to the higher specification Impact Mill, with this flexible solution, you benefit from excellent crushing results and can respond at any time to changing project requirements.

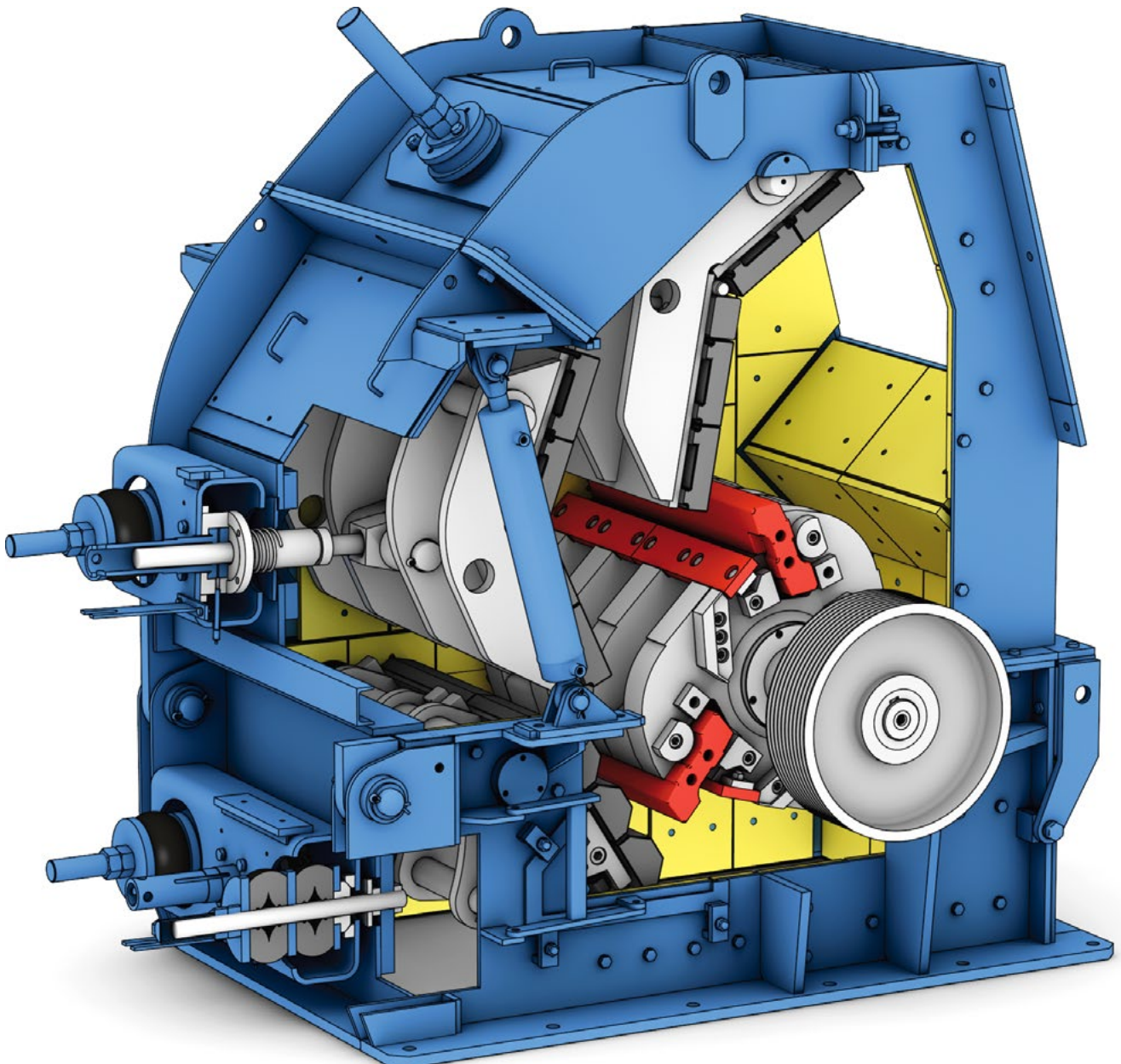

Powerful rotors

Diverse rotor variants are available, depending on the specific task. The BHS rotors are characterized by their robust welded construction. All surfaces subject to wear are fitted with wear parts that can be exchanged quickly. The blow bars are exchanged from above, with their patented mounting system making them easy to remove.

Sturdy impact plates

Depending on the specific task, the impact plates are either a robust monoblock casting or a welded steel construction with replaceable wear parts. The impact plates are not sensitive, even in the case of coarser feed materials, and can be optimally adjusted for the specific crushing application. The impact plates are supported by durable, maintenance-free spring elements.

Large feed opening

Relative to the machine size, all BHS Impact Crushers and Impact Mills have a very large feed opening. Material plugging is thus avoided and the impact chamber can be optimally utilized – even at maximum feed gradations. This allows high throughput rates and very good size reduction results.

Maintenance-friendly design

BHS machines are characterized by their durable and compact design. The housing, separable in two places, allows easy access for maintenance work, even in confined spaces.

Optimized wear components

The lining of the impact chamber consists mostly of components of the same design, thus reducing the number of parts to stock. Furthermore, the components are easy to exchange.

Flexible solution for every crushing application

Monoblock casting

- » Impact Crusher with impact plates as monoblock castings, reversible by 180°
- » Suitable for limestone or similar types of rock and for recycling concrete

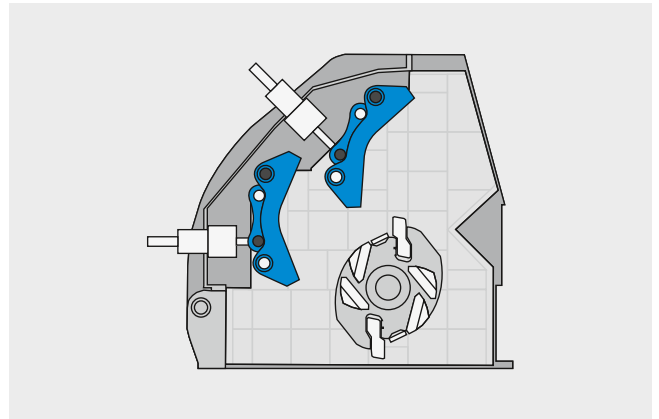

Monoblock casting with wear strips

- » Impact Crusher with impact plates as monoblock castings and screw-fastened wear strips of white iron
- » Suitable for medium-hard rock

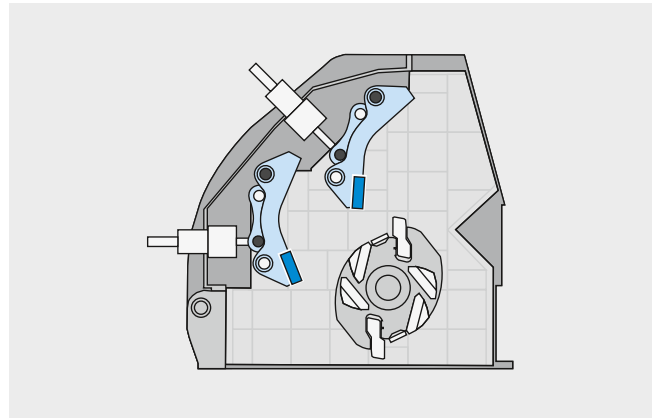

Welded construction with wear elements

- » Impact Crusher with welded impact plates and screw-fastened wear elements of white iron
- » Particularly suitable for more abrasive types of rock

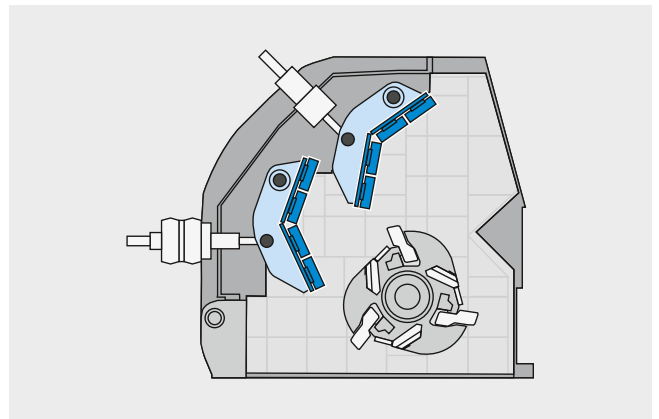

Impact Mill with additional grinding track

- » An additional grinding track beneath the rotor shaft serves to increase the size reduction ratio, improve the grain shape and enhance the proportion of crushed and broken surfaces
- » Alternative impact plates (as described above) depending on the type of rock

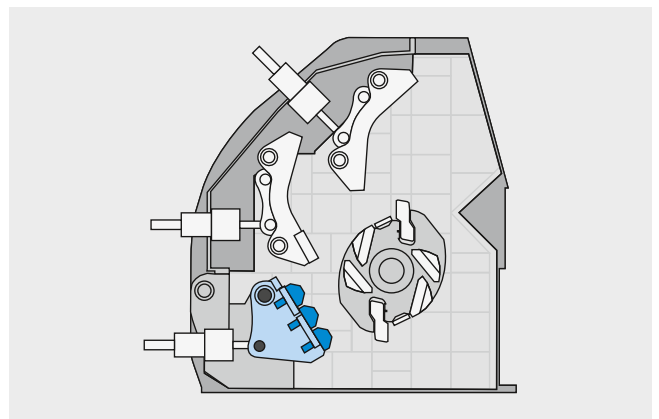

Exchanging the blow bars

Depending on the specific task, the cast blow bars are made of manganese steel or high-chromium alloy. They are fastened using a patented retaining system. This allows the blow bars to be easily released, reversed and also replaced without any difficulty. This simple retaining system saves time and labor.

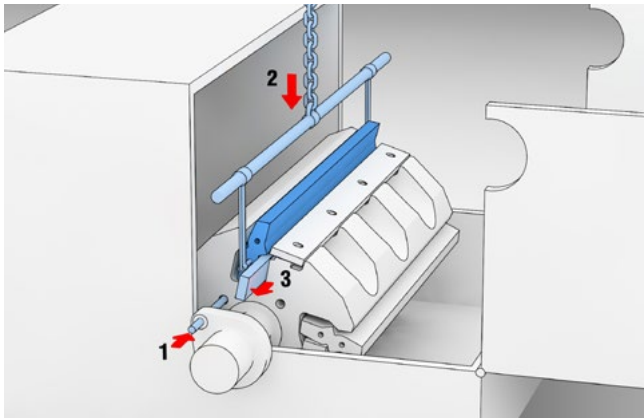

1 First the rotor is locked (1) and the blow bar is then attached to a lifting beam (2). After the retaining ledge has been pulled out to the side (3), the blow bar can be lifted upwards.

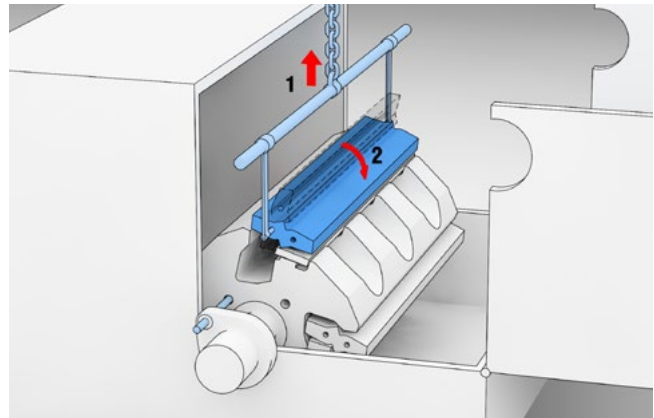

2 The blow bar is suspended eccentrically from a lifting beam. Raising the lifting beam (1) enables the blow bar to turn (2).

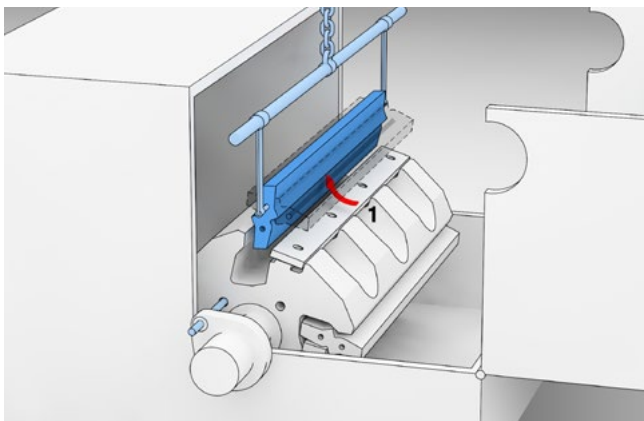

3 The blow bar automatically rotates into the new position (1).

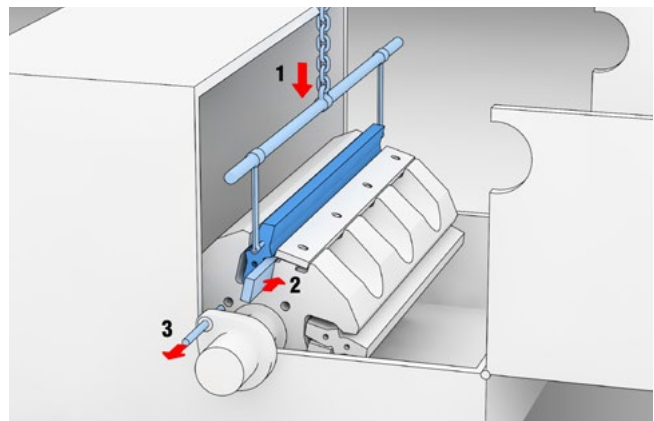

4 The blow bar can now be lowered (1) and the retaining ledge can be inserted again (2). The rotor is then unlocked (3).

Adjusting the gap width

Gap width adjustment can be carried out by one of three systems:

- » Mechanically: by means of an easy-action thread
- » Semi-automatically: at the touch of a button by means of a hydraulic cylinder or hydraulic motor
- » Fully automatically: by means of a hydraulic cylinder in conjunction with hydraulic overload protection. The gap width is set and monitored by means of an electronic controller.



BHS Impact Mill of type PM 0806 for crushing concrete for recycling and for crushing oversized gravel. The Impact Mill is replacing a jaw crusher as part of a plant modernization process.



A BHS Impact Crusher of type PB 0806 is used for crushing oversized gravel (32 to 250 mm) to produce saleable chippings.

PM 0806 for grinding sand-lime blocks (63 - 250 mm)

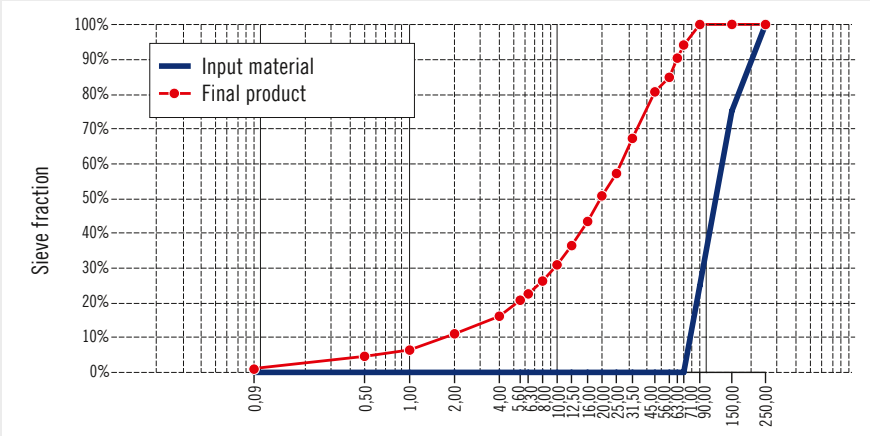

PM 0806 for grinding round gravel (31.5 - 200 mm)

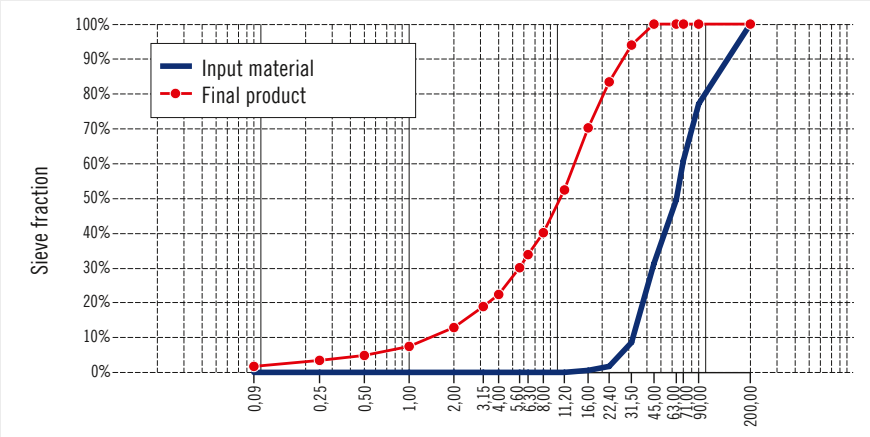

PB 0806 for crushing steel mill slag (0 - 150 mm)

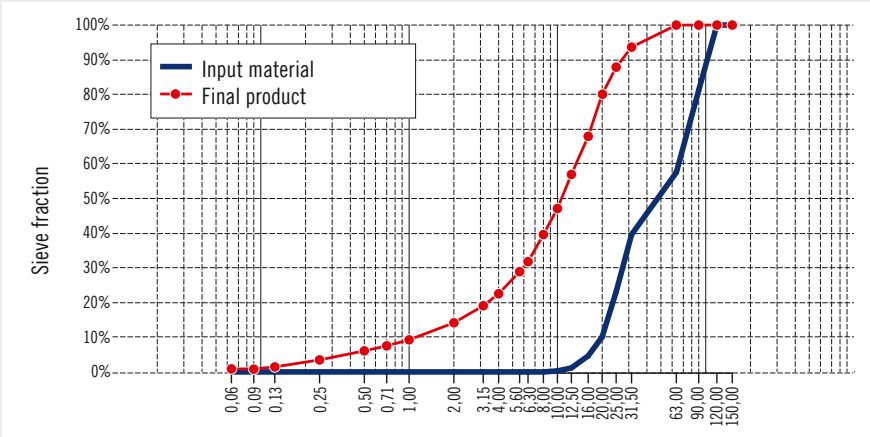

Tests give certainty

We operate an all-weather processing plant on our premises in Sonthofen. All our crushing machines are installed as production machines in this facility.

We can perform crushing tests with your input material. A variety of machine parameters can be intensively tested. This is followed by detailed evaluation of the data and a grain-size analysis which serve as the basis for the creation of an optimal machine configuration.

BHS technical center in Sonthofen for customer-specific testing



Performance data

Type	Rotor		Number of blow bars	Feed size ¹⁾ (max.)	Drive power ²⁾	Throughput ³⁾ (max.)
	Diameter	Width				
Impact Crushers						
PB 0806	800 mm	620 mm	2 (optionally 3)	400 mm	37 - 55 kW	50 t/h
PB 0810	800 mm	1,030 mm	2 (optionally 3)	400 mm	55 - 90 kW	90 t/h
PB 1010	1,000 mm	1,030 mm	3	600 mm	90 - 132 kW	135 t/h
PB 1013	1,000 mm	1,280 mm	3	600 mm	132 - 160 kW	160 t/h
PB 1212	1,250 mm	1,250 mm	4	800 mm	132 - 200 kW	225 t/h
PB 1216	1,250 mm	1,580 mm	4	800 mm	160 - 250 kW	335 t/h
Impact Mills						
PM 0806	800 mm	620 mm	2	250 mm	37 - 55 kW	40 t/h
PM 0810	800 mm	1,030 mm	2	250 mm	55 - 90 kW	70 t/h
PM 1010	1,000 mm	1,030 mm	3	300 mm	90 - 132 kW	100 t/h
PM 1013	1,000 mm	1,280 mm	3	300 mm	132 - 160 kW	120 t/h
PM 1212	1,250 mm	1,250 mm	4	350 mm	132 - 200 kW	200 t/h
PM 1216	1,250 mm	1,580 mm	4	350 mm	160 - 250 kW	300 t/h

Dimensions and weights

Type	Feed opening		Outlet flange		Transport dimensions			Weight ⁴⁾
	A	B	C	D	X	Y	Z	
Impact Crushers								
PB 0806	640 mm	650 mm	1,775 mm	1,120 mm	2,130 mm	1,590 mm	1,900 mm	4,200 kg
PB 0810	640 mm	1,070 mm	1,775 mm	1,540 mm	2,130 mm	2,150 mm	1,900 mm	5,300 kg
PB 1010	800 mm	1,060 mm	2,250 mm	1,540 mm	2,820 mm	2,180 mm	2,380 mm	10,500 kg
PB 1013	800 mm	1,330 mm	2,250 mm	1,810 mm	2,820 mm	2,450 mm	2,380 mm	11,500 kg
PB 1212	1,050 mm	1,280 mm	2,400 mm	1,940 mm	3,040 mm	2,450 mm	2,855 mm	20,000 kg
PB 1216	1,050 mm	1,580 mm	2,400 mm	2,270 mm	3,040 mm	2,750 mm	2,855 mm	23,000 kg
Impact Mills								
PM 0806	640 mm	650 mm	1,775 mm	1,120 mm	2,130 mm	1,590 mm	2,120 mm	4,600 kg
PM 0810	640 mm	1,070 mm	1,775 mm	1,540 mm	2,130 mm	2,150 mm	2,120 mm	6,100 kg
PM 1010	800 mm	1,060 mm	2,250 mm	1,540 mm	2,820 mm	2,180 mm	2,710 mm	13,600 kg
PM 1013	800 mm	1,330 mm	2,250 mm	1,810 mm	2,820 mm	2,450 mm	2,710 mm	15,000 kg
PM 1212	1,050 mm	1,280 mm	2,400 mm	1,940 mm	3,040 mm	2,450 mm	3,100 mm	22,000 kg
PM 1216	1,050 mm	1,580 mm	2,400 mm	2,270 mm	3,040 mm	2,750 mm	3,100 mm	25,000 kg

¹⁾ Maximum edge length in mm.

²⁾ Performance data for other designs available on request.

³⁾ Dependent on type of rock, rotor circumferential speed and percentage of max. particle size in the grading curve.

⁴⁾ Weight for standard design without accessories.

All specifications apply to the standard design.
 Technical data for customized designs may differ from the specified data.
 All technical data may change due to development.
 Subject to modification without notice.

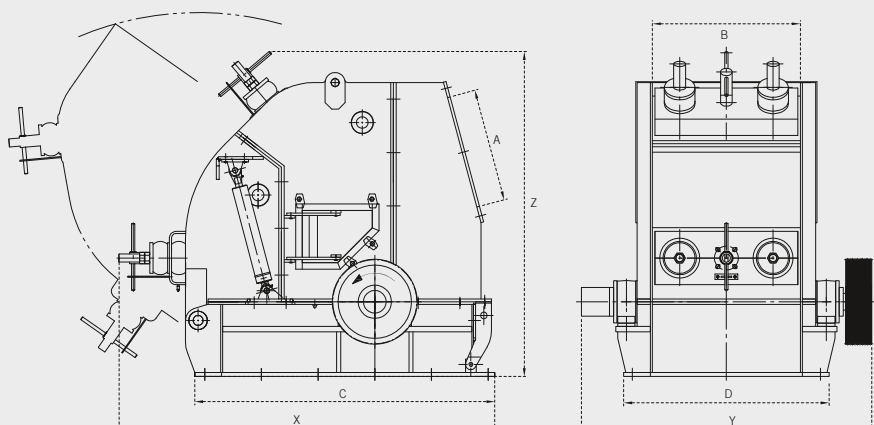

BHS FIELDS OF COMPETENCE



MIXING
TECHNOLOGY



CRUSHING
TECHNOLOGY



RECYCLING
TECHNOLOGY



FILTRATION
TECHNOLOGY

